

# AQUA CONTROL INC. CONTROL PANEL

7.5 HP, 400V, 13.0A, 50 Hz, 3-phase  
Lights: 230-240V, 1200W max

NOTE: L1 must be 230-240V to Neutral

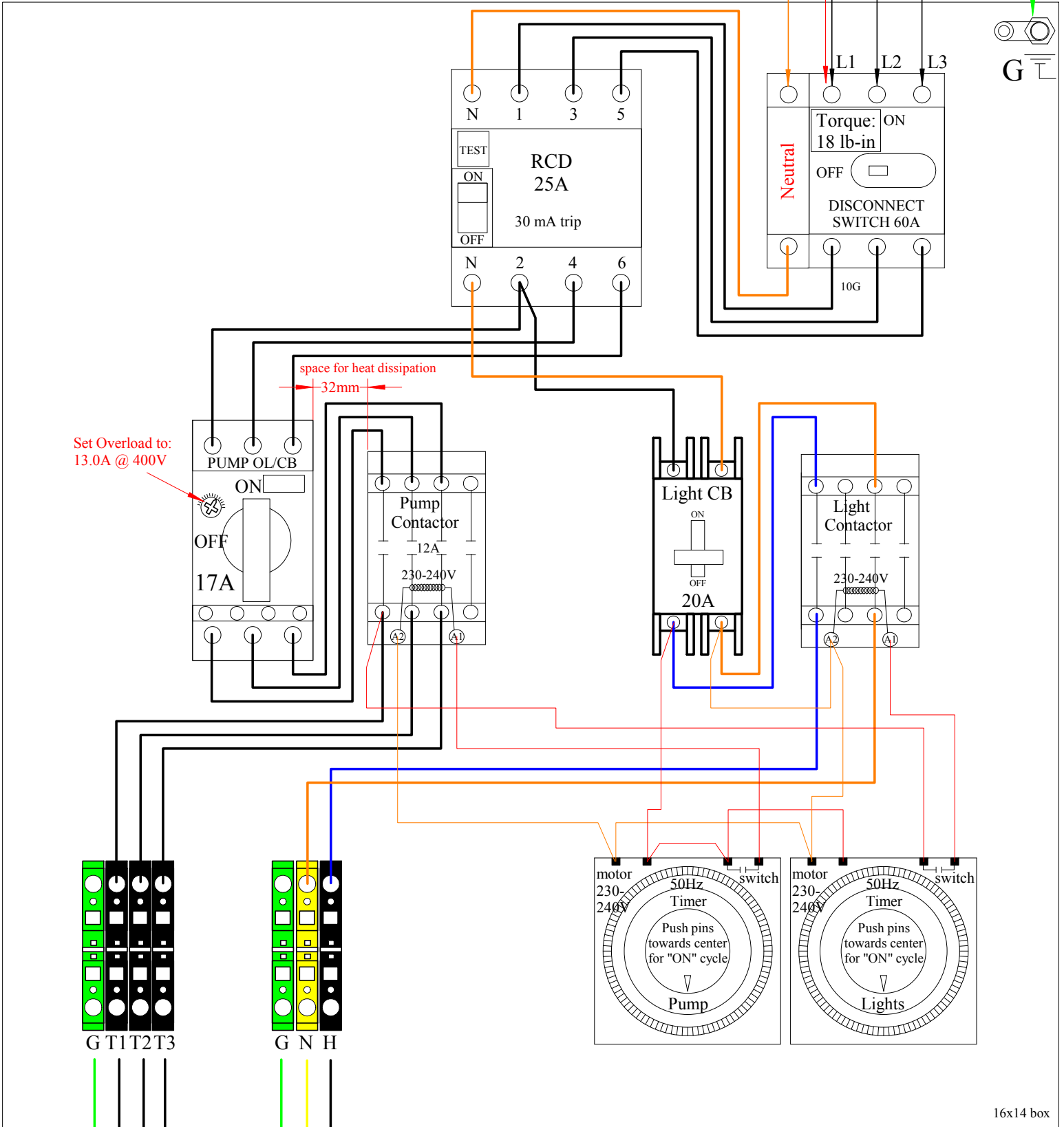

16x14 box

Pump Motor  
Model# 507533  
400V  
13.0A  
IPX8  
Max Liquid Temp: 35°C

Lights  
230-240V  
1200 watts  
IPX8

DOOR LABEL  
HP 7.5 Volts 400 Ph 3 Hz 50  
Total FLA 18.2 Motor FLA 13.0  
Model# 57533L

Aqua Control Inc.  
File: 0U5Z3P3V1L-ALAQBM-07a  
Created by: AP 8/1/07  
Revised by: AP 11/17/14