

# AQUA CONTROL INC. CONTROL PANEL

5 HP, 400V, 9.8A, 50 Hz, 3-phase  
Lights: 230-240V, 1200W max

NOTE: L1 must be 230-240V to Neutral

Incoming Neutral from 400V supply

Incoming Ground

**INCOMING 400V**

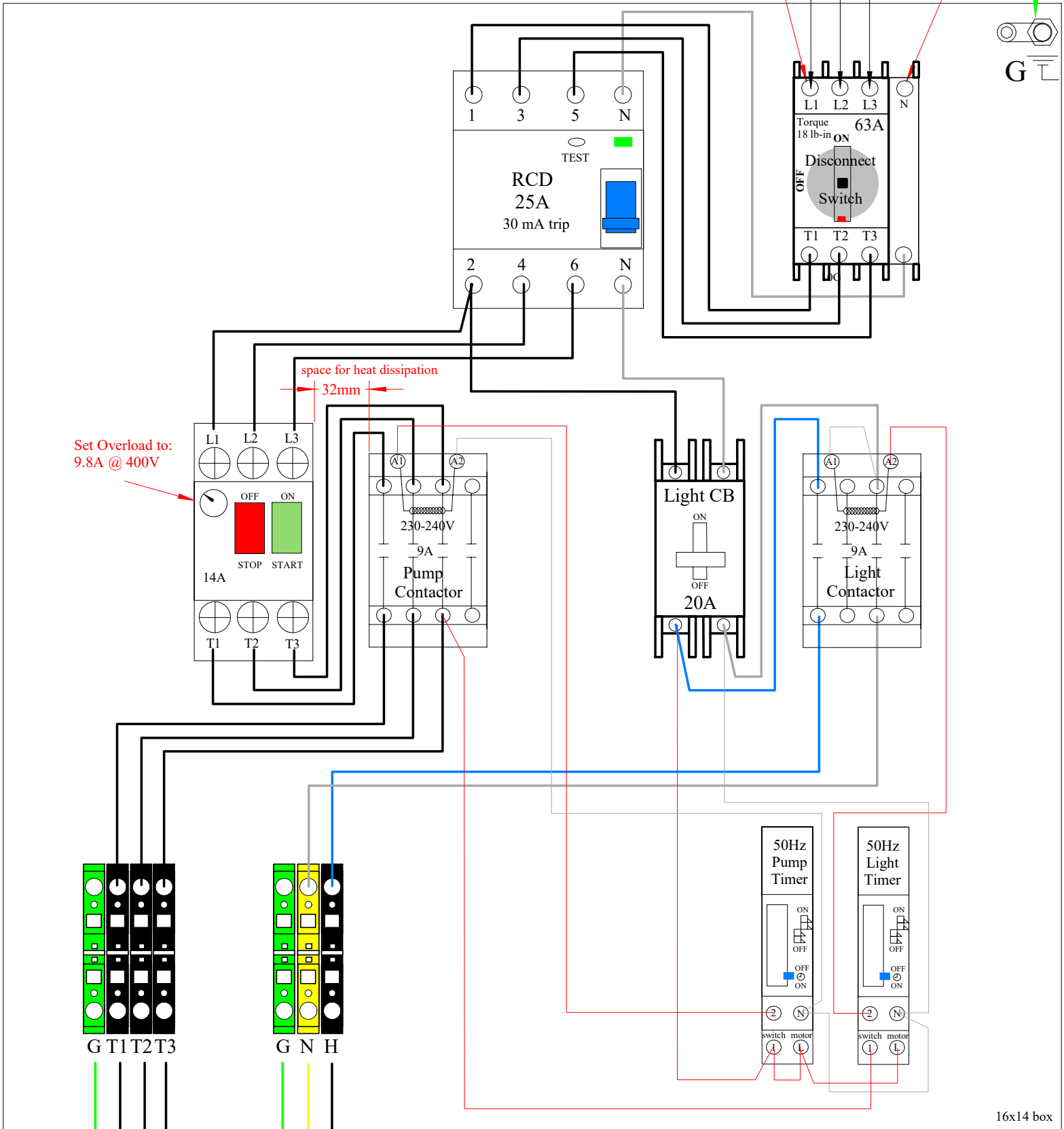

Pump Motor  
Model# 502033  
400V, 9.8A  
IPX8  
Max Liquid Temp: 35°C

Lights  
230-240V  
1200 watts  
IPX8

DOOR LABEL  
HP 5 Volts 400 Ph 3 Hz 50  
Total FLA 15 Motor FLA 9.8  
Model# 52033L

Aqua Control Inc.  
File: 0U5Z3P3V1L-ALAQBM-05f  
Created by: AP 5/31/07  
Revised by: LS 8/25/20